



屠喜(Tony) | 商务技术总监

亿登(上海)自动化技术有限公司

Eden (shanghai) Automation Technology CO.,LTD

地址:上海市闵行区陈行路2388号5号4楼401-19室(漕河泾浦江科技广场)

Address: Room P11 Buding 5, No. 2388 Chenhang Road, Minhang district, Shanghai

手机 Mobile: (+86) 139 1826 7864

电话 Phone: 021-51029898

传真 Fax: 021-51029899

邮箱 mail:sale@edenmotion.com

网址 Web: www.edenmotion.com

CIRCULAR SYSTEM AXNR

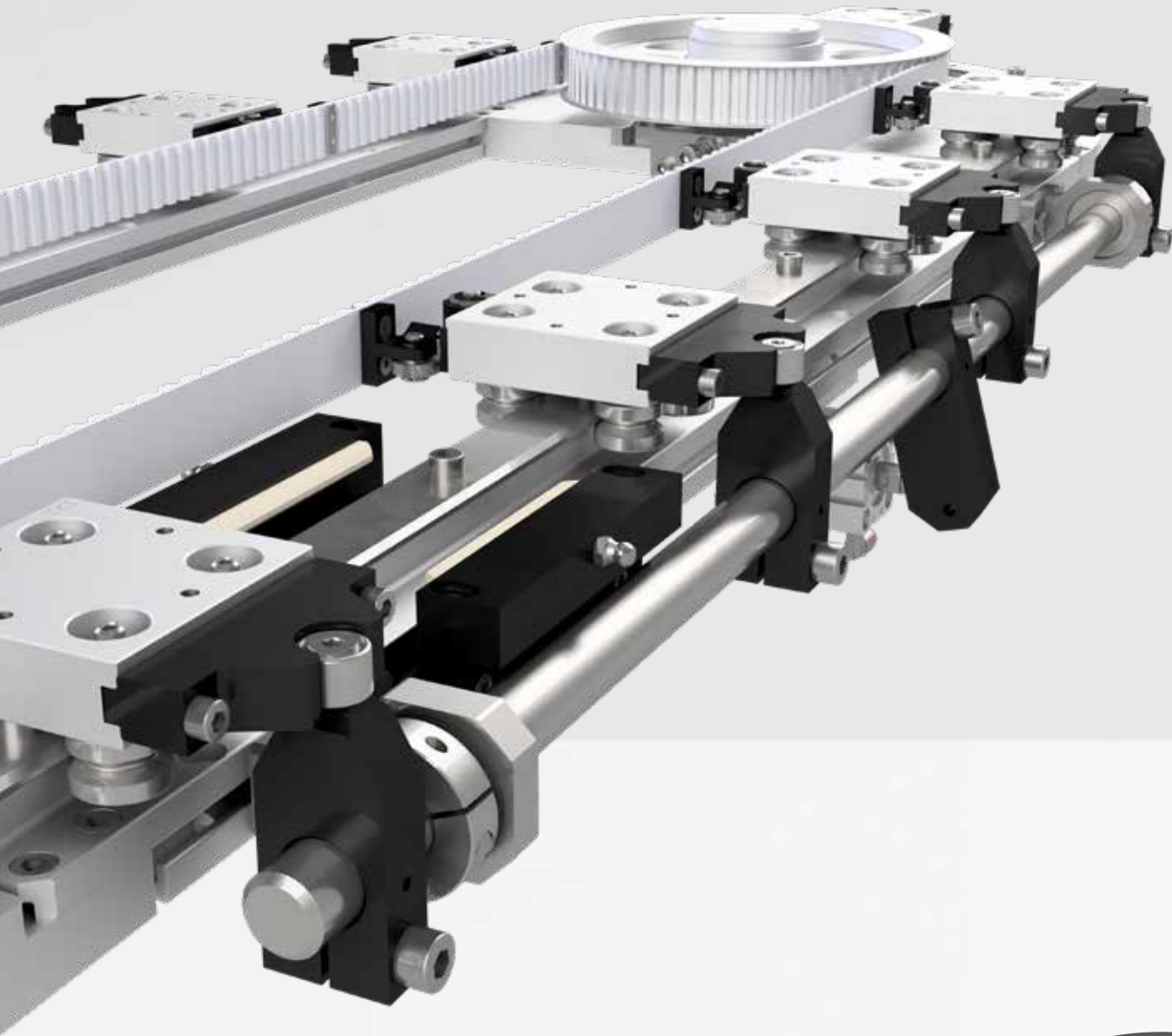



SUMMARY



PAGE 04

1.0 NADELLA GROUP

PAGE 06

2.0 PRODUCT OVERVIEW

PAGE 10

3.0 SYSTEM CONFIGURATION

- Circular rail FSRO and FSRQ
- Carriages
- Basic configurations

PAGE 16

4.0 CIRCULAR SYSTEMS

- Circular system AXNRO
- Circular system AXNRQ
- Carriage T4R
- Load, moments and operating temperature

PAGE 24

5.0 TECHNICAL FEATURES

- Drive connections and positioning system
- Circular system selection
- Applications
- Order codes

THE SPECIALIST FOR MOTION TECHNOLOGY

Nadella Group is an expert system partner for all areas of motion technology, with specialized manufacturer companies and a worldwide sales network.

Wherever innovative ideas, customized solutions, precision and reliability are required, developers and design engineers rely on products and solutions from the Nadella Group.

COMPANIES, BRANDS AND PRODUCTS OVERVIEW



durbal

Linear Guide Systems



Linear Modules



Complete Systems



Bearings and Cam Followers



Adjusting Nuts & Rings

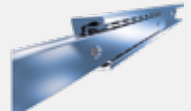

Telescopic Rails

durbal
chiavette unificate
TESCUBAL



Rod Ends and Spherical Plain Bearings



Clevises and Ball/Axial Joints



Precision Ball Screws



Rolled Ball Screws

MILESTONES

1930

NADELLA foundation in France

1958

Founding of NADELLA GMBH in Germany

1963

Founding of NADELLA S.P.A. in Italy

1984

Start of development and sale of Nadella Linear

2012

New Nadella subsidiaries in China and USA

2014

Acquisition of DURBAL

2018

Acquisition of CHIAVETTE UNIFICATE

2020

New Nadella subsidiaries in France and Spain
 Founding of Nadella Motion Technology Changxing Co. Ltd.
 Acquisition of SHUTON and IPIRANGA

KEY NUMBERS

1 Group

8 manufacturing plants

14 main locations
 Italy, Germany, France, United Kingdom, Spain, United States, China

leading the way in the international markets

in over **60** countries

for **90** years

APPLICATION SECTORS

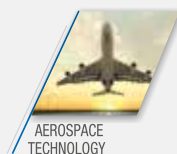
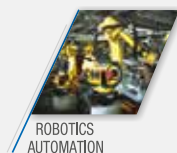
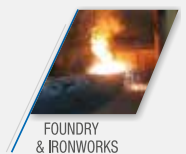

THE SPECIALIST FOR MOTION TECHNOLOGY

Our customers' satisfaction is the basis for our success and growth. That is why we are at your service around the world and always keep your requirements as a priority.

We have a worldwide network of sales engineers and distributors in Europe, Asia and the USA. This allows us to ensure customer-oriented solutions and best in class delivery and service.

WORLDWIDE NETWORK

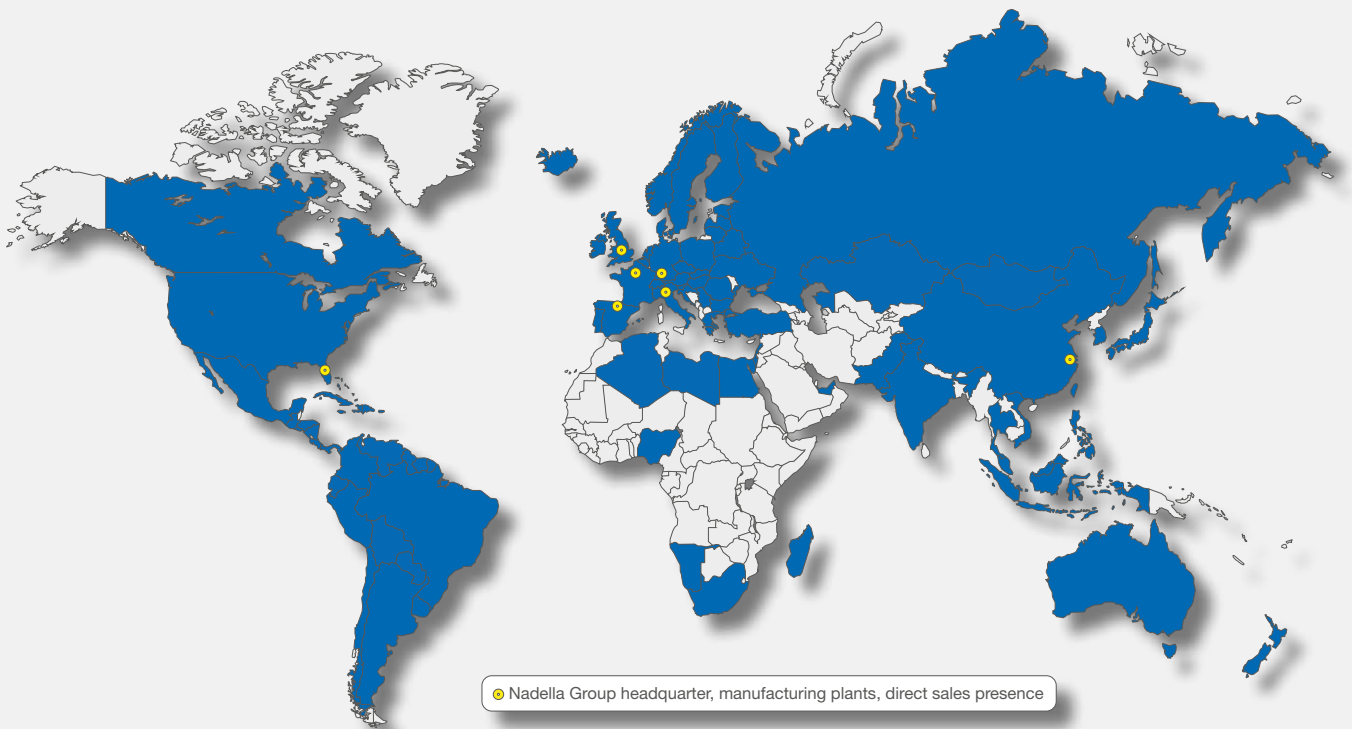

BRANCHES AND CONTACTS

NADELLA S.p.A.
Italy

Via Melette, 16
20128 Milano
Tel.: +39 02 27 093
Fax: +39 02 257 64 79
customer.service@nadella.it
www.nadella.it

NADELLA S.A.
Spain

Poligono Industrial Erratzu
Parcela G3. Pabellón 221 - Apdo.65
E-20130 Urnieta - Gipuzkoa
Tel. +34 943 336 370
ventas@nadella.es
www.nadella.com

NADELLA GmbH
Germany

Rudolf-Diesel-Str. 28
71154 Nufringen
Tel.: +49 7032 9540-0
Fax: +49 7032 9540-25
info@nadella.de
www.nadella.de

DURBAL Metallwarenfabrik GmbH - Germany

Verrenberger Weg 2
74613 Öhringen
Tel.: +49 7941 9460-0
Fax: +49 7941 9460-90
info@durbal.de
www.durbal.com

NADELLA Inc.
United States

14115 - 63 Way North
Clearwater - Florida 33760-3621
Tel.: +1 844-537-0330 (toll-free)
Fax: +1 844-537-0331
info@nadella.com
www.nadella.com

CHIAVETTE UNIFICATE S.p.A.
Italy

Via G. Brodolini 6-8-10
40069 Zola Predosa, Bologna
Tel.: +39 051 75 87 67
Fax: +39 051 75 47 80
tescubal@chivette.it
www.chivette.com

NADELLA Linear Shanghai Co. Ltd. - China

Room D314, No. 245 Xinjunhuan
RoadMinhang, Shanghai 201114
Tel.: +86 21 5068 3835
Fax: +86 21 5038 7725
info@nadellalinear.com
www.nadella.cn.com

SHUTON S.A.
Spain

Poligono Industrial Erratzu
C/Subino, 5 - 01170 LEGUTIANO
Tel.: +34 945 465 629
Fax: +34 945 465 610
shuton@shuton.com
www.shuton.com

NADELLA Sarl
France

12 Parvis Colonel Arnaud Beltrame
Hall A 4ème étage
78000 Versailles
Tel.: +33 (0)1 7319 4048
service.client@nadella.fr
www.nadella.fr

HUSILLOS IPIRANGA
Spain

Poligono Industrial Erratzu
Parcela G3. Pabellón 221 - Apdo.65
E-20130 Urnieta - Gipuzkoa
Tel. +34 943 336 370
info@ipirangahusillos.com
www.ipirangahusillos.com

DISTRIBUTORS COVERAGE

| | | | | | | | |
|---------|----------------|---------------|---------|-------------|-----------|----------|---------------|
| Austria | China | France | India | Korea | Portugal | Slovakia | Switzerland |
| Belgium | Czech Republic | Germany | Ireland | Netherlands | Romania | Slovenia | Taiwan |
| Brazil | Denmark | Great Britain | Israel | Norway | Russia | Spain | Turkey |
| Canada | Finland | Hungary | Italy | Poland | Singapore | Sweden | United States |



PRODUCT OVERVIEW



PAGE 8

2.1 PRODUCT OVERVIEW

- Circular systems
- Carriages

PAGE 9

2.2 PRODUCT DESCRIPTION

PRODUCT OVERVIEW

CIRCULAR SYSTEMS

| Type | | PAGE |
|-------|---|------|
| AXNRO |  | 18 |
| AXNRQ |  | 20 |

CARRIAGES

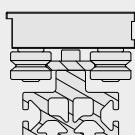
| Type | | PAGE |
|------|--|------|
| T4R |  | 22 |

PRODUCT DESCRIPTION

Nadella AXNR circular module is a further development of Nadella FSR circular rails.

AXNR module is a reliable and cost competitive solution.

The product is based on the combination of standard components to allow product definition and availability in short time.

Modification or special version to meet specific requirement are anyway possible.

The Nadella AXNR circular system is composed of groups of standard elements: aluminium basement, guide rails and carriages, transmission by gearbox and toothed belt, lubrication units and carriage indexing for precise carriage location.

AXNR circular system has following outstanding advantages:

- Nadella as leader in the V guides market provides guide rollers characterized by high load capacity, stiffness and precision, necessary to obtain regular movements and accurate positioning.
- Depending on the configuration, a special Durbal rod end design of connection between toothed belt and carriages provides a steady and smooth moving of entire system.
- Aluminium alloy machined base directly connected to the gearbox lead to a space-saving system, meanwhile a steady and easy-mounting solution.
- Customized solution and complete system are available thanks to flexible configuration

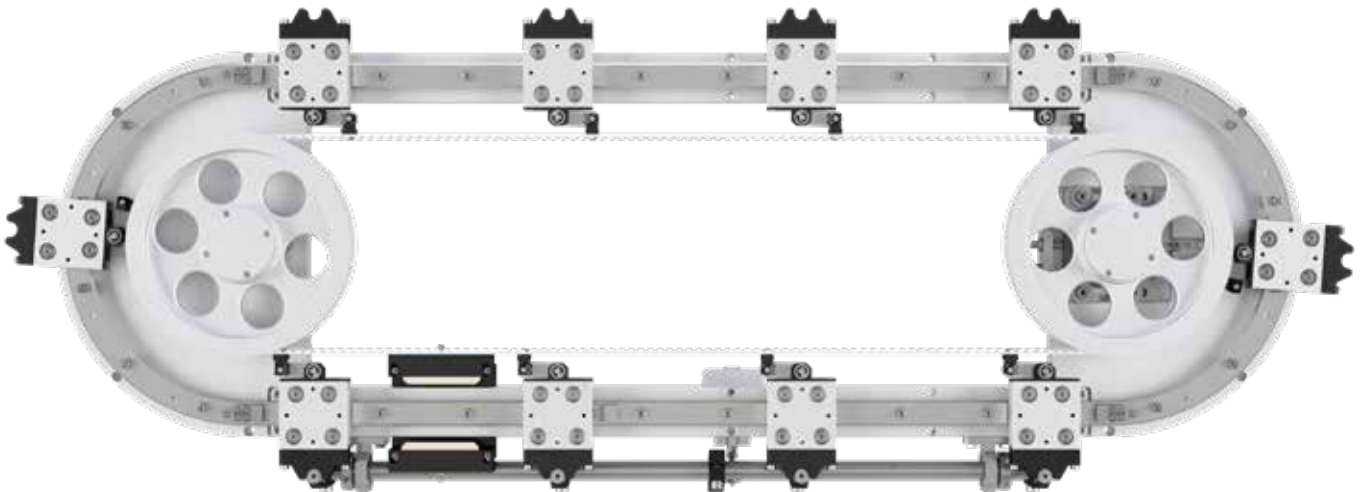

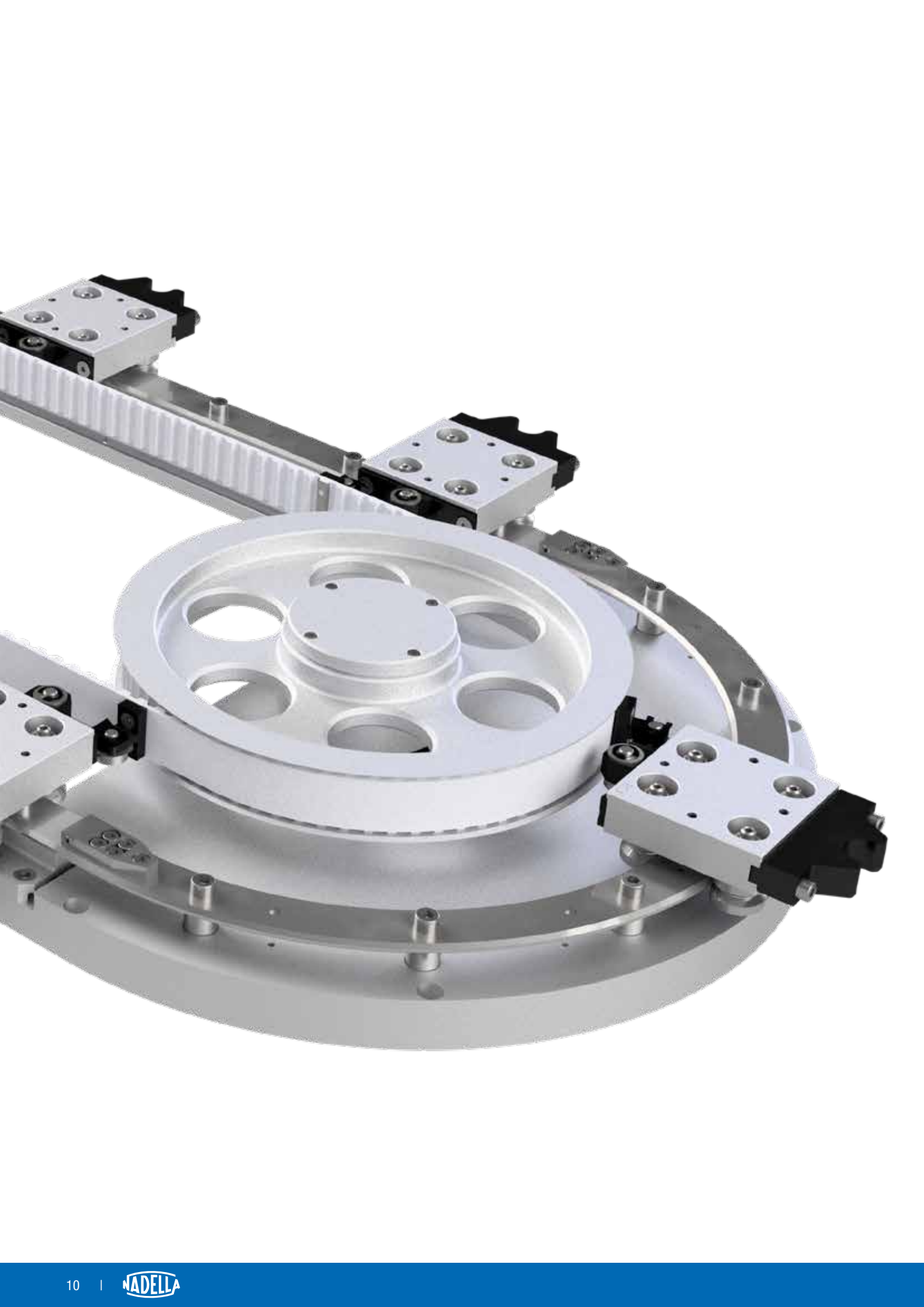

SYSTEM CONFIGURATION

3

| | |
|----------------|--|
| PAGE 12 | 3.1 CIRCULAR RAIL FSRO AND FSRQ |
| PAGE 13 | 3.2 CARRIAGES |
| PAGE 14 | 3.3 BASIC CONFIGURATION |

SYSTEM CONFIGURATION CIRCULAR RAIL FSRQ AND FSRQ

Circular rails are induction hardened on raceway to achieve life and ground to improve surface finish and accuracy. Circular rails are composed of both circular and straight parts. When the systems dimensions become excessive for shipment in a preassembled unit alignment blocks provide a simple way to align the joints between two parts. In this case it's convenient to ask for a short removable piece of rail to simplify the carriage insertion on the assembled unit (Option 13).

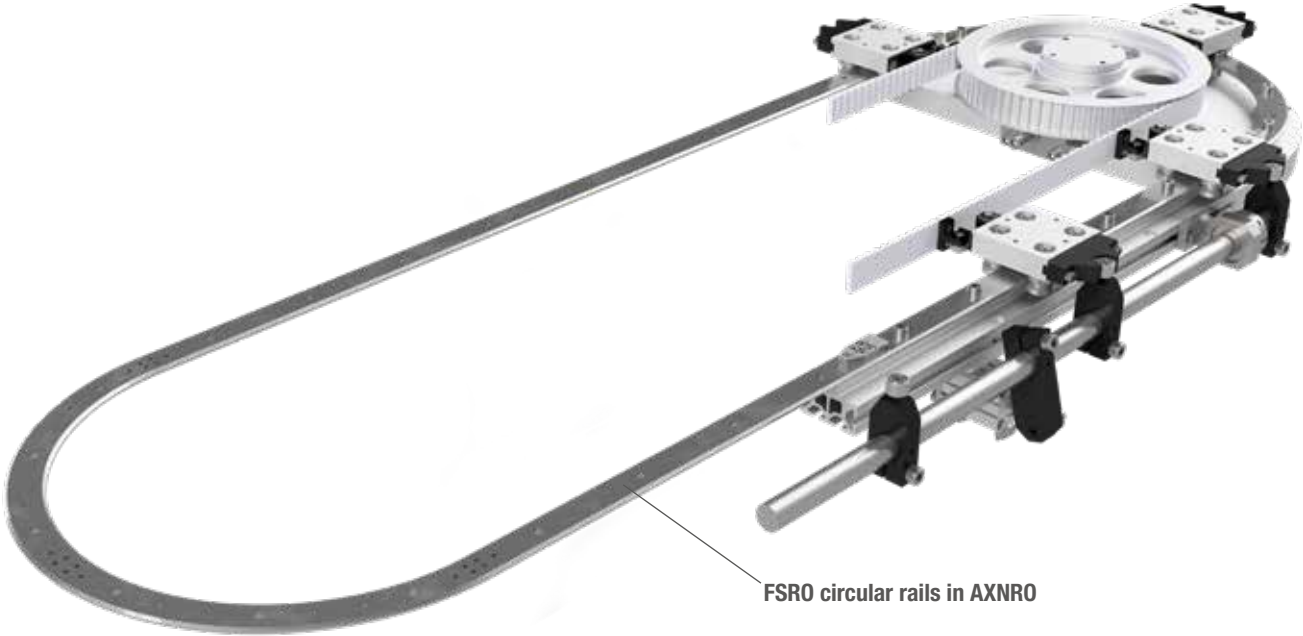

Nadella circular module AXNRO is made of oval circuit FSRQ. AXNRQ is made of ring circuit FSRQ.

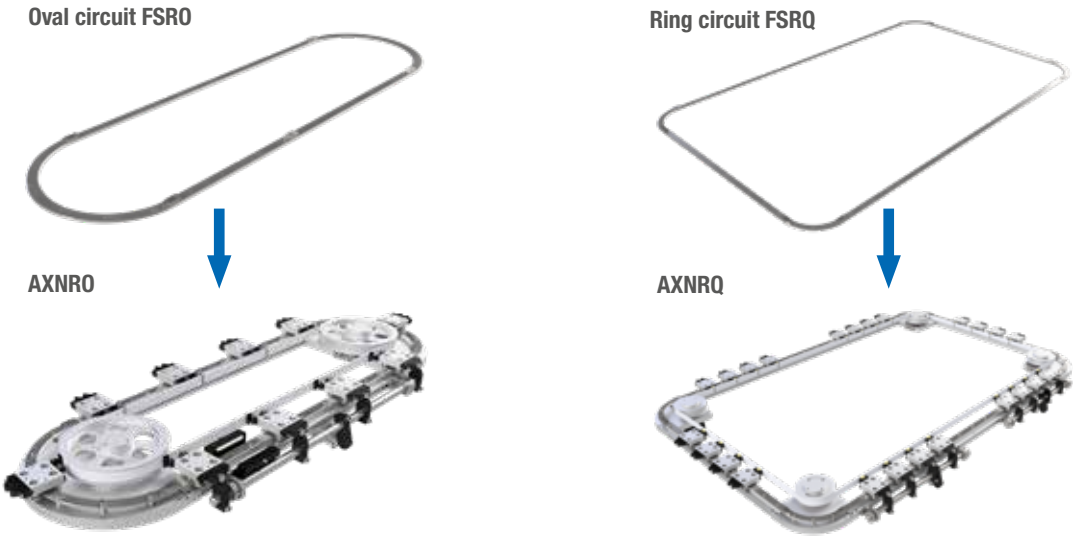

SYSTEM CONFIGURATION CARRIAGES

Carriages equipped with Nadella guide rollers supporting the load in all directions. Standard carriages with rollers in fixed position to allow precise movement in the round and in the stright section of the guide rail circuit. Carriage preload is set already in the factory for a ready to use product.

The carriage is equipped with two concentric guide rollers and two eccentric guide rollers. The eccentric guide rollers are mounted on the inner side of the circuit and allow to set the preload.

Normal preload is registered already in the factory for a ready to use product, but on request higher or lower preload can be required.

The preload remains constant on the straight and on the round path, but during the transition, when two rollers are on the round rail and the other two are on the straight rail, the preload is lost and a small play between the rollers and the guide occurs.



Concentric roller FR...EU



Eccentric roller FRR...EU

The carriage body is based on an anodized aluminium plate. Additional machining as reference holes can be easily done. Special carriage design to fit the application requirement are always feasible.

CORROSION RESISTANT CARRIAGES

Guides and guide rollers in stainless steel are part of the standard Nadella range and carriages in anticorrosion version can be easily configured.

Most applications with anticorrosion requirement use stainless steel rollers in aluminium table and other steel components, as the cam for carriage location, protected by nickel plating. Fully stainless solution can be provided on request.



SYSTEM CONFIGURATION

BASIC CONFIGURATION

TRANSMISSION

Carriage traction is based on toothed belt for silent and maintenance free transmission. Design focused to reduce the distance from the belt to the carriage in order to minimize the peak-load on the carriage connection at high speed during the transition from round to straight path.

Carriage distance has to be a multiple of the belt pitch: 10 mm up to rail radius 300 mm and 20 mm for radius 400 and 500. The length of the module depends from the length of the belt. For carriages at constant pitch, the most common configuration, the belt length is calculated as the number of carriages by their pitch. The module length will fit the required belt length.

FLOATING CONNECTION

Toothed belt and carriages are linked by a floating connection to provide a reliable movement and the compensation of distance between belt and carriage on the round path.

Two types of connectors available: A type based on Durbal rod end and B type based on direct engagement.

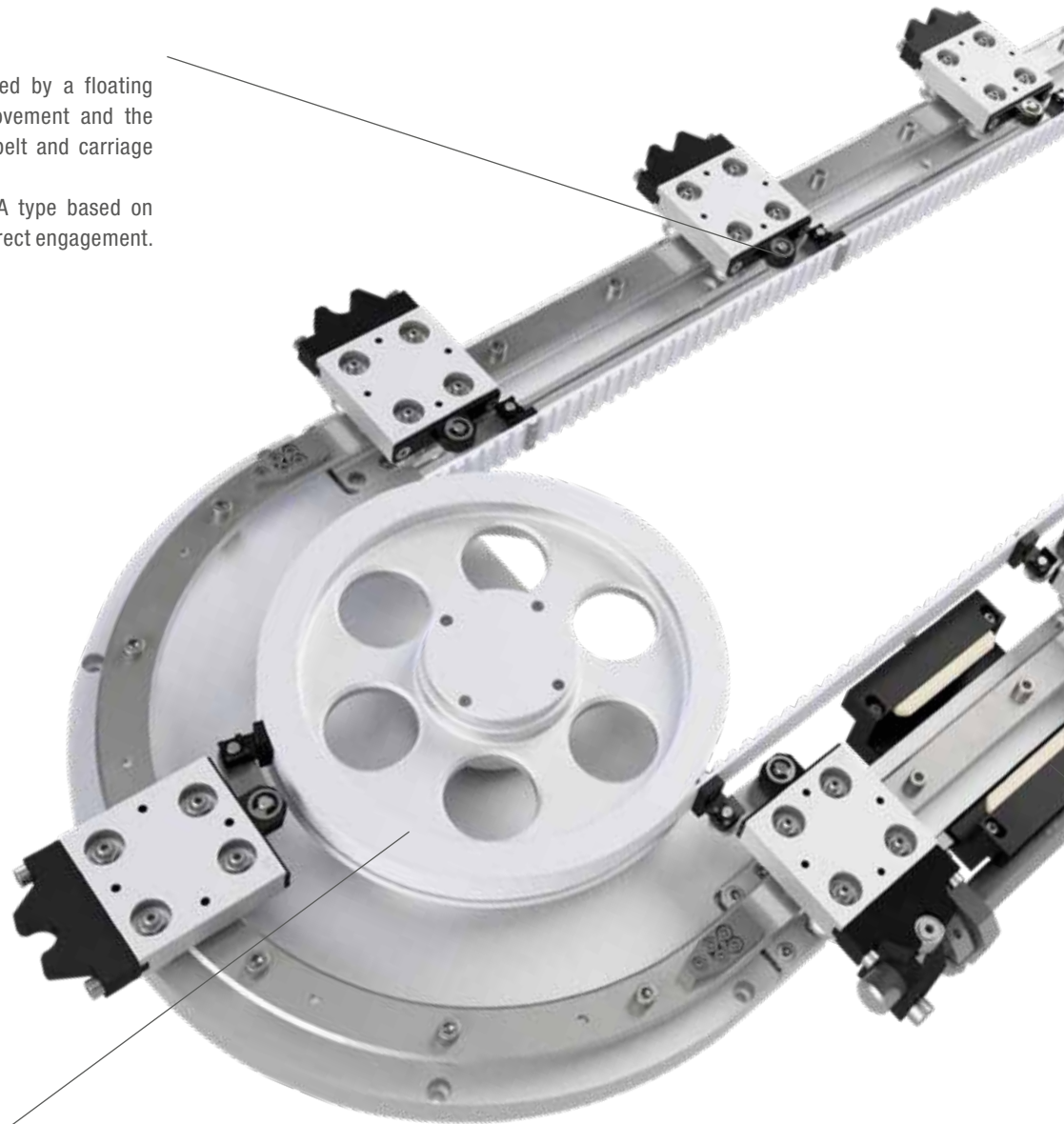

DYNAMIC SYSTEM

Drive pulley directly mounted on the gear box output shaft for maximum integration. First class gear box to achieve high dynamic and accuracy performances are delivered configured already with the proper interface for the specific customer motor.

On request specific gear box can be supplied.

ALUMINIUM ALLOY BASE

The module basement is made in aluminium. It is composed by the main plates supporting the pulleys and the profiles to support the linear guide rails. It's a compact solution that allows to save space in the equipment.

For long modules it's necessary to support the module to avoid excessive stress and deformation in the structure.

The extruded profiles supporting the linear rails have T slots along their length used to fix options as lubricators and carriage indexing cam in any position.

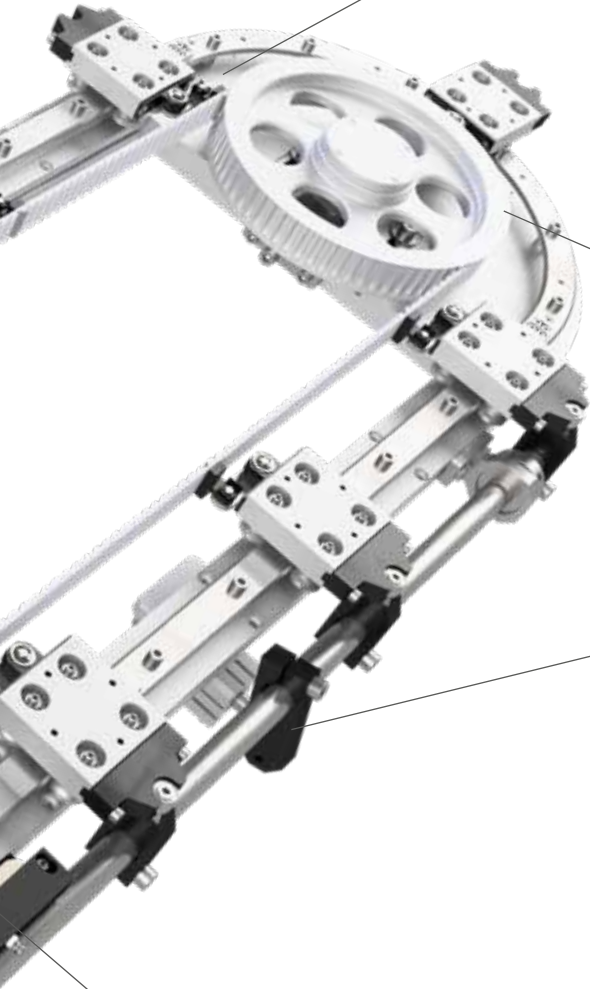

IDLER PULLEY

Idler pulley is mounted on a slide to allow belt tensioning.

POSITIONING SYSTEM (OPTIONAL)

The positioning system guarantees the repeating accuracy of carriage position



LUBRICATION

Nadella LUBR system is an easy mounting solution. The lubrication oil stored in the foam is directly released to the surface of the guide rollers minimizing the oil consumption. The reservoir effect of the foam allows to reduce the maintenance activity for lubrication.





CIRCULAR SYSTEMS

4

PAGE 18

4.1 CIRCULAR SYSTEM AXNRO

PAGE 20

4.2 CIRCULAR SYSTEM AXNRQ

PAGE 22

4.3 CARRIAGE T4R

PAGE 23

4.4 LOAD, MOMENTS AND OPERATING TEMPERATURE

CIRCULAR SYSTEMS

AXNRO



Available in
EVO version

EVO

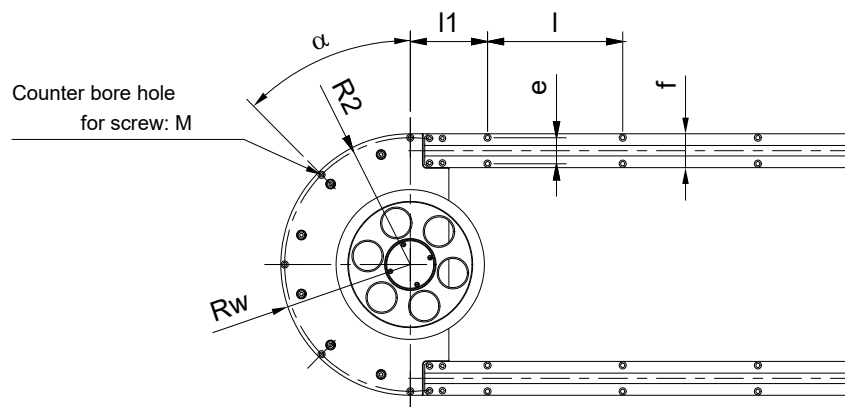
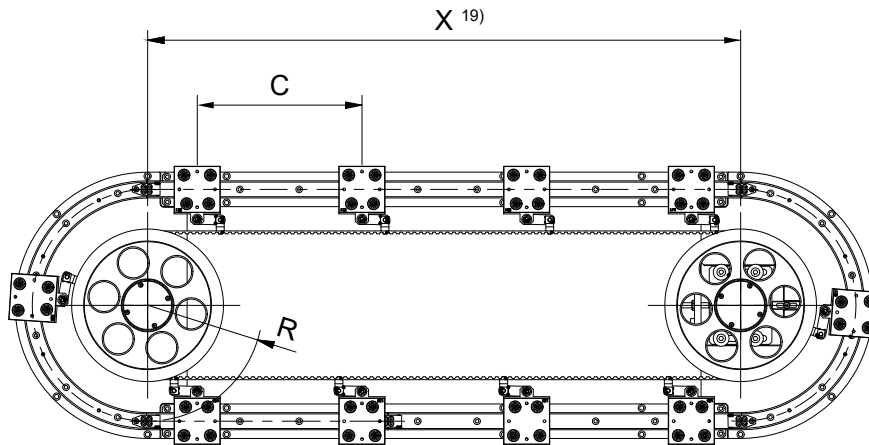
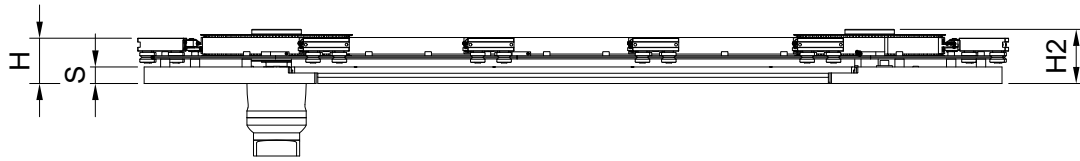

4.1

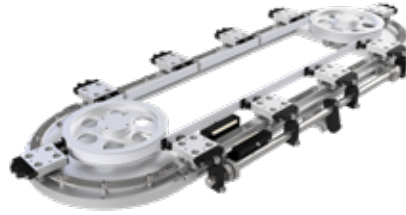

Available in
EVO version

EVO

| Type | R ¹⁾ mm | R _w ²⁾ mm | GRS ³⁾ | BT ⁴⁾ | Z ⁵⁾ | H ⁶⁾ mm | H ₂ ⁷⁾ mm | S mm | R ₂ ⁸⁾ mm | α ⁹⁾ ° | f ¹⁰⁾ | l ₁ ¹¹⁾ mm | l ¹²⁾ mm | d ¹³⁾ mm | D ¹⁴⁾ mm | h ¹⁵⁾ mm | e ¹⁶⁾ mm | WxL ¹⁷⁾ kg | WxAL ¹⁸⁾ kg |
|-----------|-----------------------|------------------------------------|-------------------|-------------------|-----------------|-----------------------|------------------------------------|---------|------------------------------------|----------------------|------------------|-------------------------------------|------------------------|------------------------|------------------------|------------------------|------------------------|--------------------------|---------------------------|
| AXNRO 75 | 75 | 101 | FS22M | AT10-25 | 17 | 68,5 | 80 | 25 | 95 | 60x3 | 52 | 120 | 200 | 6,6 | 11 | 4 | 40 | 14,3 | 6,6 |
| AXNRO 125 | 125 | 151 | FS22M | AT10-25 | 40 | 68,5 | 82 | 25 | 145 | 45x4 | 52 | 120 | 200 | 6,6 | 11 | 4 | 40 | 19,7 | 6,6 |
| AXNRO 175 | 175 | 201 | FS22M | AT10-25 | 70 | 68,5 | 82 | 25 | 195 | 45x4 | 52 | 120 | 200 | 6,6 | 11 | 4 | 40 | 27,4 | 6,6 |
| AXNRO 225 | 225 | 265 | FS35M | AT10-32 / AT20-32 | 85 / 42 | 83 | 95 | 25 | 256 | 45x4 | 80 | 140 | 200 | 9 | 15 | 8/21 | 62 | 54,4 | 13 |
| AXNRO 300 | 300 | 340 | FS35M | AT10-32 / AT20-32 | 130 / 64 | 83 | 95 | 25 | 331 | 45x4 | 80 | 140 | 200 | 9 | 15 | 8/21 | 62 | 73,0 | 13 |
| AXNRO 400 | 400 | 460 | FS47M | AT20-50 | 90 | 102 | 125 | 30 | 450 | 22,5x8 | 120 | 180 | 200 | 11 | 18 | 10/26 | 100 | 186 | 24,5 |
| AXNRO 500 | 500 | 560 | FS47M | AT20-50 | 120 | 102 | 125 | 30 | 550 | 22,5x8 | 120 | 180 | 200 | 11 | 18 | 10/26 | 100 | 245 | 24,5 |

1) Circular guide radius

2) Aluminum base radius

3) Guide rail size

4) Belt Type

5) Number of teeth in pulley Z

6) See the technical drawing at page 22 for details

7) Distance between module mounting surface and upper surface of belt wheel

8) Distribution radius of mounting hole

9) Distribution angle of mounting hole

10) Aluminum beam width

11) Hole spacing at the beginning of line segment

12) Hole spacing of straight line

13) Counterbore hole perforation diameter

14) Counterbore hole diameter

15) Counterbore hole depth

16) Hole spacing

17) Approximate weight for module length X = 1 m (without carriages)

18) Weight for additional length

19) Length of module in X direction. Length is the distance between the rail centres, see page 30 for details and calculation method

CIRCULAR SYSTEMS

AXNRQ



Available in
EVO version

EVO

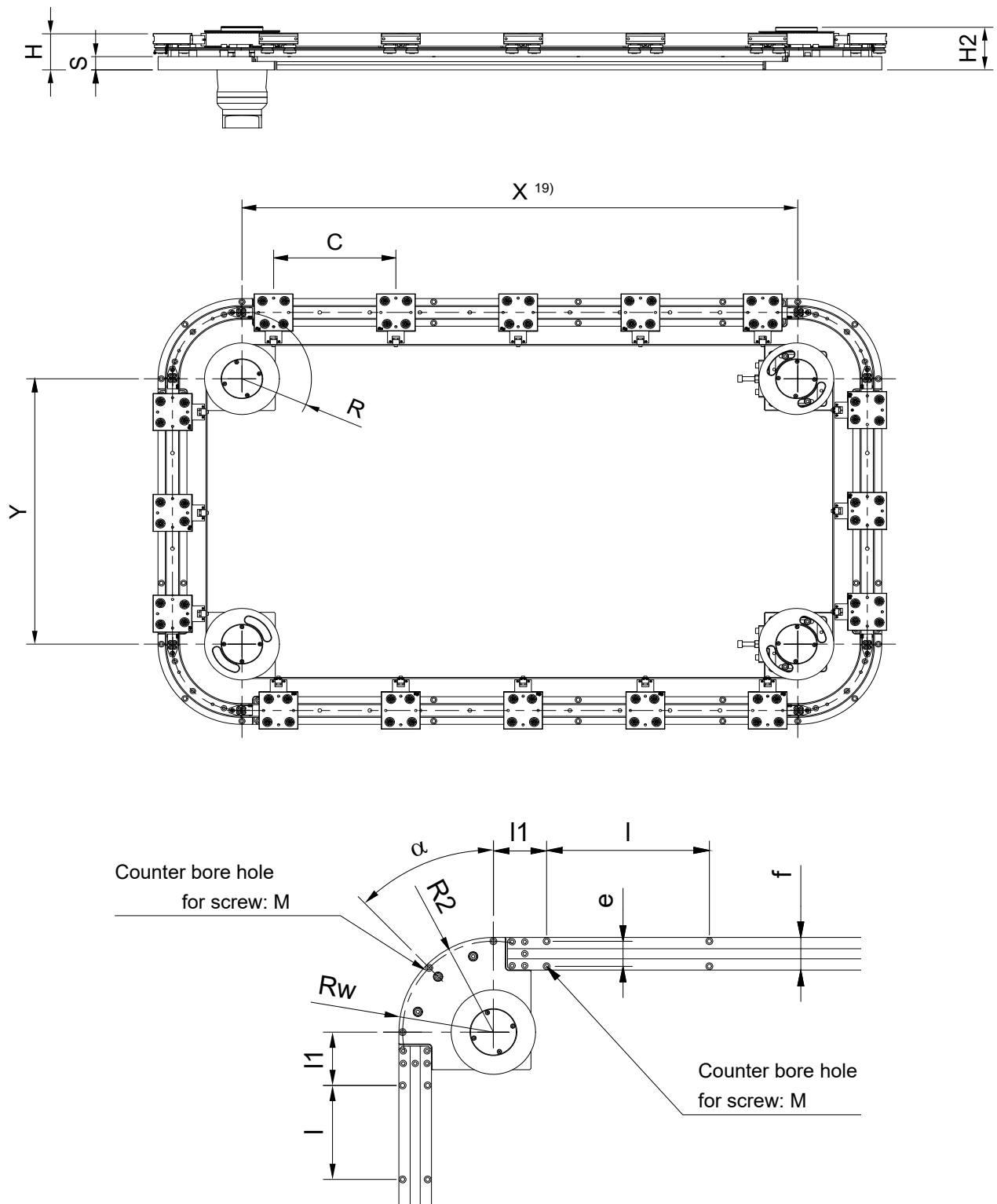

4.2



Available in
EVO version

EVO

| Type | R ¹⁾ mm | R _w ²⁾ mm | GRS ³⁾ | BT ⁴⁾ | Z ⁵⁾ | H ⁶⁾ mm | H ₂ ⁷⁾ mm | S mm | R ₂ ⁸⁾ mm | α ⁹⁾ ° | f ¹⁰⁾ | l ₁ ¹¹⁾ mm | l ¹²⁾ mm | d ¹³⁾ mm | D ¹⁴⁾ mm | h ¹⁵⁾ mm | e ¹⁶⁾ mm | W _{xL} ¹⁷⁾ kg | W _{xAL} ¹⁸⁾ kg |
|-----------|-----------------------|------------------------------------|-------------------|-------------------|-----------------|-----------------------|------------------------------------|---------|------------------------------------|----------------------|------------------|-------------------------------------|------------------------|------------------------|------------------------|------------------------|------------------------|--------------------------------------|---------------------------------------|
| AXNRQ 75 | 75 | 101 | FS22M | AT10-25 | 17 | 68,5 | 80 | 25 | 95 | 45x2 | 52 | 120 | 200 | 6,6 | 11 | 6 | 40 | 23,4 | 6,6 |
| AXNRQ 125 | 125 | 151 | FS22M | AT10-25 | 40 | 68,5 | 82 | 25 | 145 | 45x2 | 52 | 120 | 200 | 6,5 | 11 | 6 | 40 | 32,9 | 6,6 |
| AXNRQ 175 | 175 | 201 | FS22M | AT10-25 | 70 | 68,5 | 82 | 25 | 195 | 45x2 | 52 | 120 | 200 | 6,6 | 11 | 6 | 40 | 43,5 | 6,6 |
| AXNRQ 225 | 225 | 265 | FS35M | AT10-32 / AT20-32 | 85 / 42 | 83 | 95 | 25 | 256 | 45x2 | 80 | 140 | 200 | 9 | 15 | 8/21 | 62 | 76,9 | 13 |
| AXNRQ 300 | 300 | 340 | FS35M | AT10-32 / AT20-32 | 130 / 64 | 83 | 95 | 25 | 331 | 45x2 | 80 | 140 | 200 | 9 | 15 | 8/21 | 62 | 106 | 13 |
| AXNRQ 400 | 400 | 460 | FS47M | AT20-50 | 90 | 102 | 125 | 30 | 450 | 22,5x4 | 120 | 180 | 200 | 11 | 18 | 10/26 | 100 | 276 | 24,5 |
| AXNRQ 500 | 500 | 560 | FS47M | AT20-50 | 120 | 102 | 125 | 30 | 550 | 22,5x4 | 120 | 180 | 200 | 11 | 18 | 10/26 | 100 | 370 | 24,5 |

1) Circular guide radius

2) Aluminum base radius

3) Guide rail size

4) Belt Type

5) Number of teeth in pulley Z

6) See the technical drawing at page 22 for details

7) Distance between module mounting surface and upper surface of belt wheel

8) Distribution radius of mounting hole

9) Distribution angle of mounting hole

10) Aluminum beam width

11) Hole spacing at the beginning of line segment

12) Hole spacing of straight line

13) Countersunk hole perforation diameter

14) Countersunk hole diameter

15) Countersunk hole depth

16) Hole spacing

17) Approximate weight for module length X = 1 m (without carriages)

18) Weight for additional length

19) Length of module in X direction. Length is the distance between the rail centres, see page 30 for details and calculation method

CIRCULAR SYSTEMS

CARRIAGE T4R

4.3

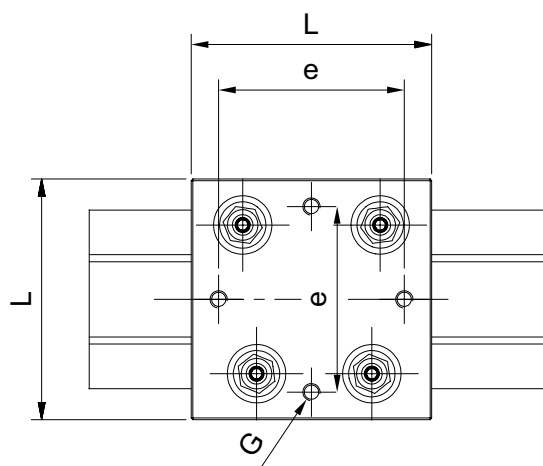
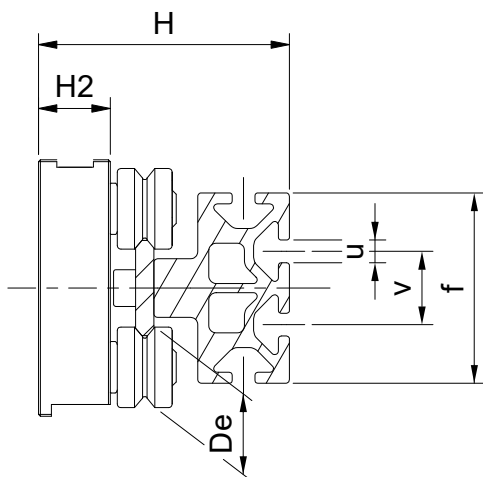

| Type | L mm | D _e mm | e mm | G | H mm | H ₂ mm | U | V | f | Weight ¹⁾ kg | Combinations |
|--------------------|---------|----------------------|---------|-----|---------|----------------------|-----|------|-----|----------------------------|--------------|
| T4R 75 FR22EU-... | 70 | 22 | 54 | M5 | 68,5 | 19,6 | 6,2 | 20 | 52 | 0,40 | AXNR 75 |
| T4R 125 FR22EU-... | 70 | 22 | 54 | M5 | 68,5 | 19,6 | 6,2 | 20 | 52 | 0,40 | AXNR 125 |
| T4R 175 FR22EU-... | 70 | 22 | 54 | M5 | 68,5 | 19,6 | 6,2 | 20 | 52 | 0,40 | AXNR 175 |
| T4R 225 FR32EU-... | 110 | 32 | 90 | M8 | 83 | 27,4 | 6,2 | 40 | 80 | 1,22 | AXNR 225 |
| T4R 300 FR32EU-... | 110 | 32 | 90 | M8 | 83 | 27,4 | 6,2 | 40 | 80 | 1,22 | AXNR 300 |
| T4R 400 FR40EU-... | 150 | 40 | 126 | M10 | 102 | 29,5 | 6,2 | 2x30 | 120 | 2,50 | AXNR 400 |
| T4R 500 FR40EU-... | 150 | 40 | 126 | M10 | 102 | 29,5 | 6,2 | 2x30 | 120 | 2,50 | AXNR 500 |

1) Weight without locating CAM

CONNECTORS

Connector type A with Durbal tie rod is available for AXNR radius 125 175 225 300 mm.

Connector type B is available for all dimensions.

| AXNR radius | Belt type | Carriage model | |
|-------------|-----------|---------------------|---------------------|
| | | Connector type A | Connector type B |
| 75 | AT10-25 | | T4R75 FR22EU-B ... |
| 125 | AT10-25 | T4R125 FR22EU-A ... | T4R125 FR22EU-B ... |
| 175 | AT10-25 | T4R175 FR22EU-A ... | T4R175 FR22EU-B ... |
| 225 | AT10-32 | T4R225 FR32EU-A ... | |
| | AT20-32 | | T4R225 FR32EU-B ... |
| 300 | AT10-32 | T4R300 FR32EU-A ... | |
| | AT20-32 | | T4R300 FR32EU-B ... |
| 400 | AT20-50 | | T4R400 FR40EU-B ... |
| 500 | AT20-50 | | T4R500 FR40EU-B ... |

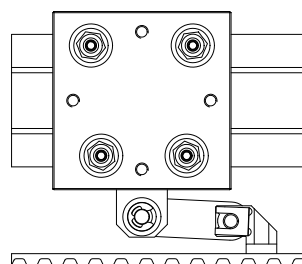

Connector type A

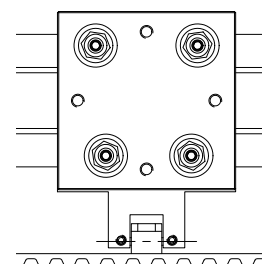

Connector type B

CIRCULAR SYSTEMS

LOAD, MOMENTS AND OPERATING TEMPERATURE

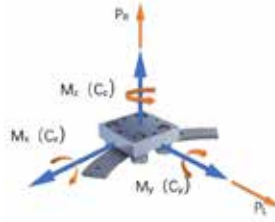

MAXIMUM LOADS ON SINGLE CARRIAGE

The following table shows the maximum loads that can be applied on a single carriage.

| Module | Carriage | F _y | F _z | M _x | M _y | M _z |
|------------|------------------|----------------|----------------|----------------|----------------|----------------|
| AXNR.. 75 | T4R75FR22EU-... | 2800 | 1680 | 18 | 26 | 48 |
| AXNR.. 125 | T4R125FR22EU-... | 2800 | 1680 | 18 | 28 | 51 |
| AXNR.. 175 | T4R175FR22EU-... | 2800 | 1680 | 18 | 30 | 53 |
| AXNR.. 225 | T4R225FR32EU-... | 4000 | 3200 | 63 | 95 | 130 |
| AXNR.. 300 | T4R300FR32EU-... | 4000 | 3200 | 63 | 100 | 130 |
| AXNR.. 400 | T4R400FR40EU-... | 7300 | 5600 | 190 | 250 | 350 |
| AXNR.. 500 | T4R500FR40EU-... | 7300 | 5600 | 190 | 250 | 350 |

The maximum loads are based on the stud and bearing strengths. The loads in the table are considered as acting singularly. For applications with many loads acting at the same time the loads must be reduced.

BASIC DYNAMIC LOADS OF SINGLE CARRIAGE

The following table shows the nominal loads that correspond to a nominal life of the bearing at 100 km. The nominal lifetime of the carriage can be estimated from the standard bearing formula

$$L_{10} = (C_i / P_i)^3 \times 100 \text{ km}$$

C_i is the basic dynamic load capacity in a specific direction i and P_i is the external load applied in the same specific direction.

| Module | Carriage | F _y | F _z | M _x | M _y | M _z |
|------------|------------------|----------------|----------------|----------------|----------------|----------------|
| AXNR.. 75 | T4R75FR22EU-... | 5800 | 4000 | 43 | 62 | 100 |
| AXNR.. 125 | T4R125FR22EU-... | 5800 | 4000 | 43 | 67 | 105 |
| AXNR.. 175 | T4R175FR22EU-... | 5800 | 4000 | 43 | 72 | 110 |
| AXNR.. 225 | T4R225FR32EU-... | 11600 | 8500 | 165 | 250 | 375 |
| AXNR.. 300 | T4R300FR32EU-... | 11600 | 8500 | 165 | 260 | 375 |
| AXNR.. 400 | T4R400FR40EU-... | 17000 | 12000 | 400 | 550 | 800 |
| AXNR.. 500 | T4R500FR40EU-... | 17000 | 12000 | 400 | 550 | 800 |

C_i is the basic dynamic load capacity in a specific direction i and P_i is the external load applied in the same specific direction.

CALCULATION EXAMPLE: CARRIAGE LOADED WITH AN EXTERNAL LOAD F

Carriage T4R225 FR32EU-A-00
F = 2000 N

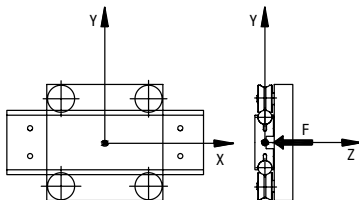

The external load F acts in the z-axis direction: P_z = F = 2000

In the table of the “maximum loads” you find that the load capacity F_z for carriage T4R225 FR32EU is equal to 3200, so the system is validated against breakage. To estimate the system lifetime we proceed as follows: from the table of the “basic dynamic loads” we see that C_z, for the carriage T4R225 FR32EU, is equal to 8500.

The nominal lifetime will be:

$$L_{10} = (8500 / 2000)^3 \times 100 = 7676 \text{ Km}$$

The admissible load on the system depends on guide rollers load capacity and on the retention force of the connector between carriage and belt.

The tables in this page allow the selection of AXNR module size, based on guide roller load capacity, speed and accelerations involved.

The belt transmission, in fact, is subject to inertia forces due to the duty cycle and due to the centrifugal acceleration between the straight and curved path.

This second acceleration becomes consistent when increasing the velocity and usually defines the max admissible speed of the carriage. For a system mounted in horizontal plane and with the payload mass centred on the carriage with connector B type the graph here below allows a preliminary evaluation.

Moreover, mass position on the carriage and module orientation strongly affect the load on the belt.

Contact our Technical Service to better evaluate your load conditions. See page 30 and Application Form for the data to be used for the dimensional verifying.

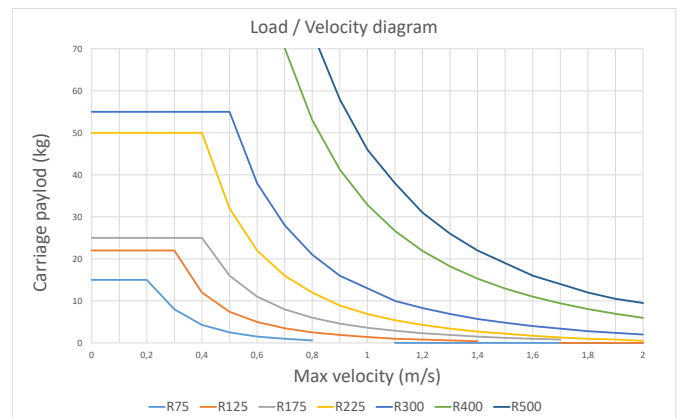

OPERATING TEMPERATURE

The standard operating temperature is between -10°C and +70°C. Out of this range, please contact the Nadella technical support.



TECHNICAL FEATURES

5

PAGE 26

5.1 DRIVE CONNECTIONS AND POSITIONING

- Direct gearbox connection
- Positioning system
- Transverse reinforcements

PAGE 30

5.2 CIRCULAR SYSTEM DEFINITION ELEMENTS

PAGE 31

5.3 APPLICATION FORM

PAGE 32

5.4 APPLICATION EXAMPLES

- Test line
- Bottling line
- Battery assembly line
- High speed conveyor

PAGE 36

5.5 SPARE PARTS

PAGE 37

5.6 ORDER CODES

- AXNR System
- Carriage

TECHNICAL FEATURES

DRIVE CONNECTIONS AND POSITIONING

DIRECT GEARBOX CONNECTION



The gearbox is directly connected to the aluminium alloy base of AXNR Circular System.

Planetary gearbox with reinforced bearings are used to support the belt tension and to allow precise movement.

Depending on the available space it is possible to select the axial gearbox or the 90° angle gearbox. Gearbox is complete of flange and finished accordingly with the motor type used by the customer.

In most cases a two stages gearbox is selected to achieve the right balancing between speed and torque.

The table here below shows approximate dimensions and available ratios for the two stages gearbox.

Precise dimension can be defined with the specific motor flange type identification.

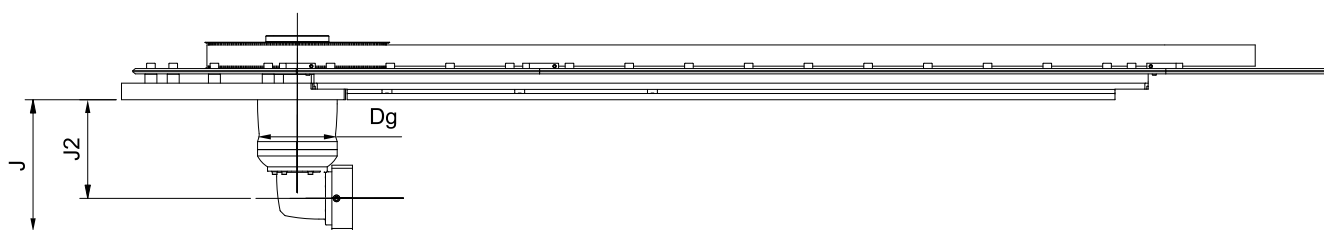
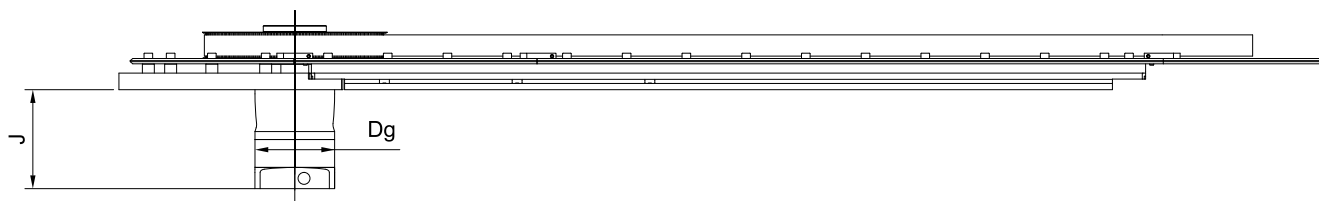

| Type | Gear box body size Dg | Axial version J | Angle version J2/J | Available gear box ratio |
|--|-----------------------|-----------------|--------------------|--|
| AXNRO / AXNRQ 75 | 50 | 70 | 57 / 77 | 9-12-15-16-20-25-28-30-32-35-40-50-64-70-100 |
| AXNRO / AXNRQ 125 AXNRO / AXNRQ 175 | 90 | 111 | 99 / 140 | 9-12-15-16-20-25-28-30-32-35-40-50-64-70-100 |
| AXNRO / AXNRQ 225 AXNRO / AXNRQ 300 | 120 | 142 | 139 / 197 | 9-12-15-16-20-25-28-30-32-35-40-50-64-70-100 |
| AXNRO / AXNRQ 400 AXNRO / AXNRQ 500 | 155 | 172 | 178 / 253 | 20-25-32-40-50-60-64-100 |

POSITIONING SYSTEM

AXNR positioning system has been developed especially for precise circular applications. The system is driven by an air cylinder located below the straight module beam. The cylinder rotates the indexer shaft equipped with cam followers that engage in the locating cam fixed on the carriages. The system allows repeatability in the carriage location of ± 0.05 mm. One or several positioning systems can be mounted on the module to index all carriages or some carriages only.

BEFORE

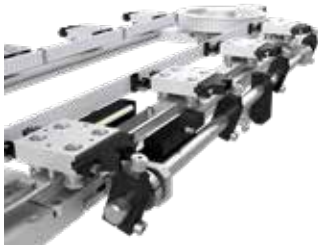

Avoid the moving carriage

AFTER

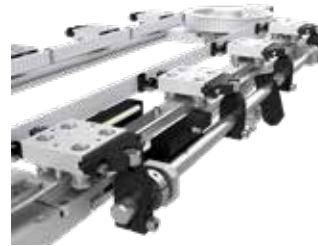

Automatic positioning system

When the positioning system is used carriages are equipped with locating cam.

Locating cam

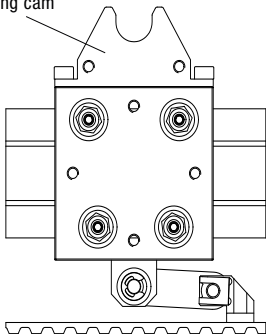

Positioning system is driven by pneumatic cylinder. Consider there is a space below the system and beside the carriages required for the air cylinder.

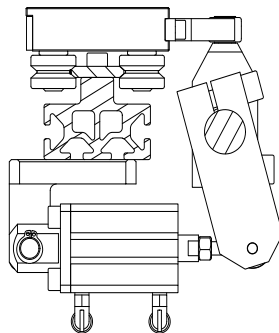

One cylinder is used to activate several positioning cam follower. Normal maximum length for a single unit up to 2000 mm.

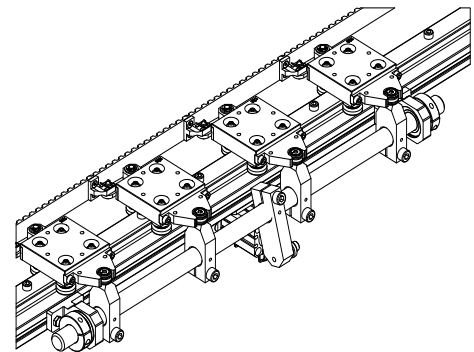

TRANSVERSE REINFORCEMENT

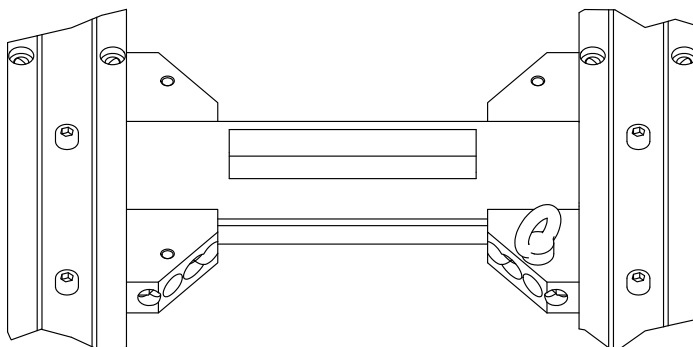

In case of long or heavy modules these can be provided with transversal supports (Option 14).

The supports are linked to the structure with angular connectors equipped with threaded holes to accommodate eyebolts.

TECHNICAL FEATURES

DRIVE CONNECTIONS AND POSITIONING

INDUCTIVE PROXIMITY SENSORS KIT

In case a reference point is required, inductive proximity sensors can be used. The sensor can be easily fixed on the aluminium profile and reads a ferromagnetic target positioned on the carriage cam.

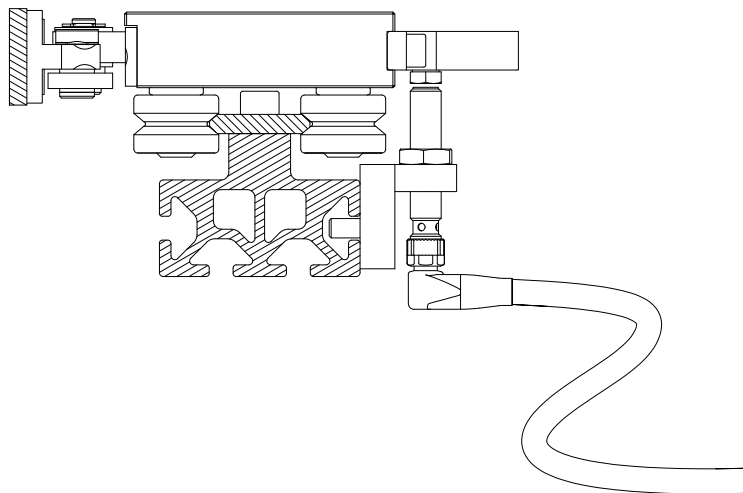

| Kit | AXNR size | Sensor | Connected voltage | Max load current | Switching precision | Cable length | Protection class |
|------------|-----------|-----------------------------------|-------------------|------------------|---------------------------|--------------|------------------|
| 20.036.610 | 22 | Switch i4 PNP-NO (Normally Open) | 10 ... 30 V DC | 200 mA | ≤ 10% of sensing distance | 5m | IP 67 |
| 20.036.620 | 22 | Switch i4 PNP-NC (Normally Close) | | | | | |
| 20.055.610 | 35 | Switch i4 PNP-NO (Normally Open) | | | | | |
| 20.055.620 | 35 | Switch i4 PNP-NC (Normally Close) | | | | | |

Each kit is composed by one sensor, with its cable and its holder and one ferromagnetic target.

NOTE

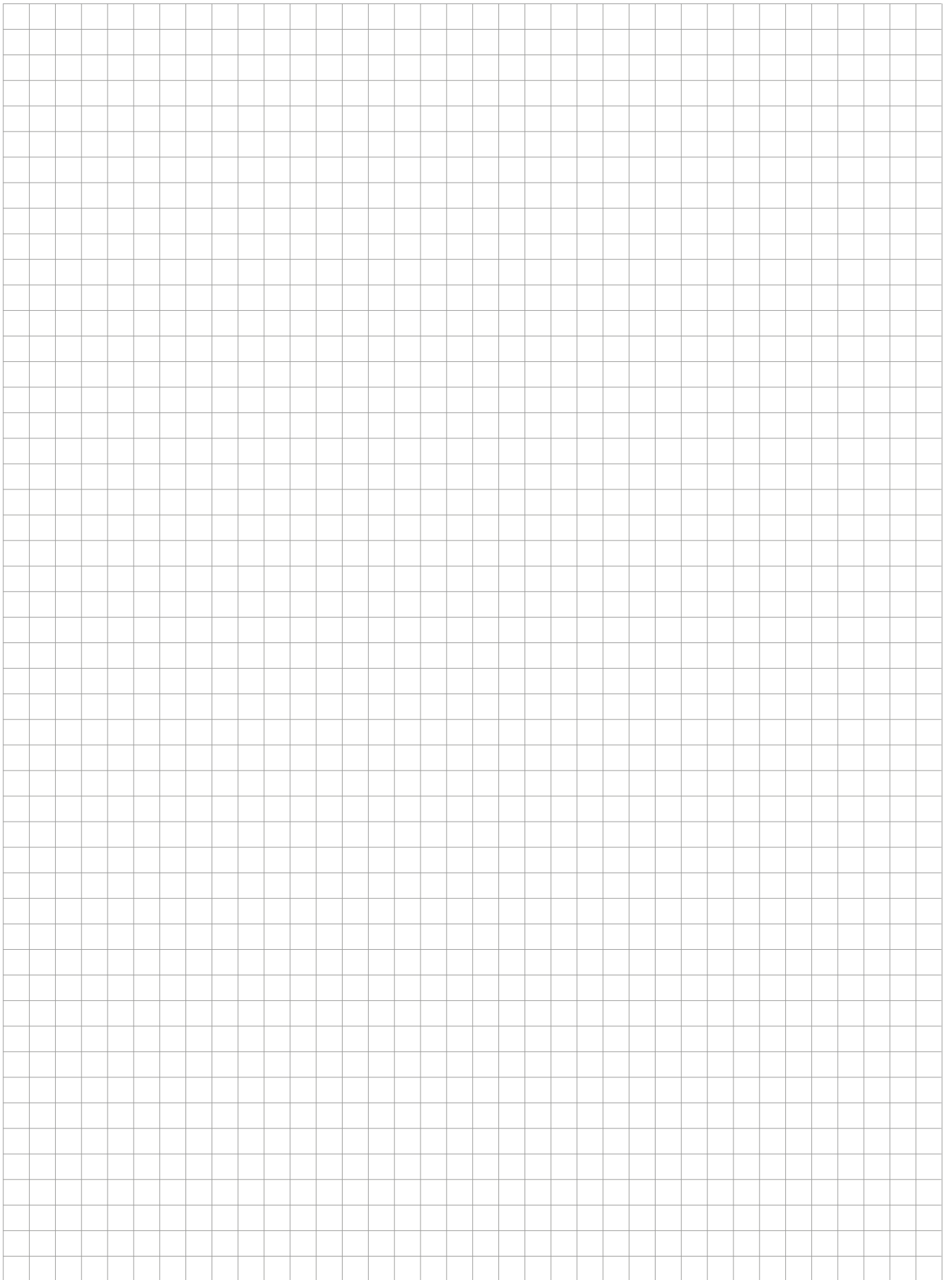
A large grid of graph paper, consisting of 20 columns and 30 rows of small squares, intended for taking notes.

TECHNICAL FEATURES

CIRCULAR SYSTEM DEFINITION ELEMENTS

5.2

For the definition of the AXNR system proceed as follows:

1. Define the application requirement: weight and dimension of the mass to be handled, additional forces acting on the carriage, expected system life, module orientation in the space, environment condition as cleanness, temperature, cycle details as stroke, acceleration, velocity, cycle time.
2. Select the carriage dimension accordingly with the load and carriage load capability. Data in the tables allow calculation in simple cases, refer to Nadella service for assistance.
3. Decide which configuration is desired (AXNO or AXNRQ) and how many carriages are needed.
4. Estimate the module dimensions as follows. The dimensions depend on the belt length. In most cases the carriages are at constant pitch and the belt length is calculated as the number of carriages by the carriage distance (carriage distance has to be multiple of the belt pitch). From the belt length deduct the length of belt around pulleys (the belt pitch by the number of teeth of the full pulley Z). The result is the length of the belt parallel to the straight path. Divide this value by 2. For AXNRQ this result is a first approximation of the module Length X. For AXNRQ decide the desired width dimension Y and deduct it. The X length here calculated is a theoretical length, actual system length X has to be increased of few mm to compensate the elongation of the belt during the assembly (needed elongation is defined by Nadella during the product definition phase).
5. Choose gearbox type, lubricator position, carriage positioning system and other options. For AXNRQ modules define in which corner the drive pulley has to be located.
6. Fill in the application form and submit it to Nadella. It will simplify the technical evaluation and offering process.

AXNR APPLICATION FORM

5.3

AXNR Application Form

| | |
|---------------------|--|
| Company | |
| Contact person | |
| Phone | |
| email | |
| date | |
| Project designation | |

Application Data

| | | |
|--|---------------------|--|
| Equipment type / Application description | | |
| AXNR type (AXNR0 or AXNRQ) | | |
| AXNR radius (75, 125, 175...) | | |
| AXNRQ Width Y (useless value for AXNR0) | | |
| Mark the drive pulley position | | |
| System orientation [Horizontal, Lateral, Vertical] | | |
| Number of carriages | | |
| Distance between carriages [mm] | | |
| Mass M applied on the carriage [kg] | | |
| Mass position [mm] | X= Y = Z = | |
| Additional force F acting on the carriage | Fx= Fy = Fz = | |
| Additional force position | X= Y = Z = | |
| Complete Cycle time [s] | | |
| Stroke time (time to move from one position to the next one) [s] | | |
| Acceleration [m/s ²] | | |
| Max velocity [m/s] | | |
| Carriage locating system [Yes / No] | | |
| Number of positions with carriage locating system | | |
| Gear box type [Axial / 90° angle] | | |
| Gear box ratio 1:... | | |
| Other requirements (corrosion resistance, temperature range, ...) | | |

TECHNICAL FEATURES APPLICATION EXAMPLES

TEST LINE

This high efficiency space-saving test line is possible due to the combination of the AXNRO Circular System and AXN actuators, which provides an automatic unmanned solution on every process.

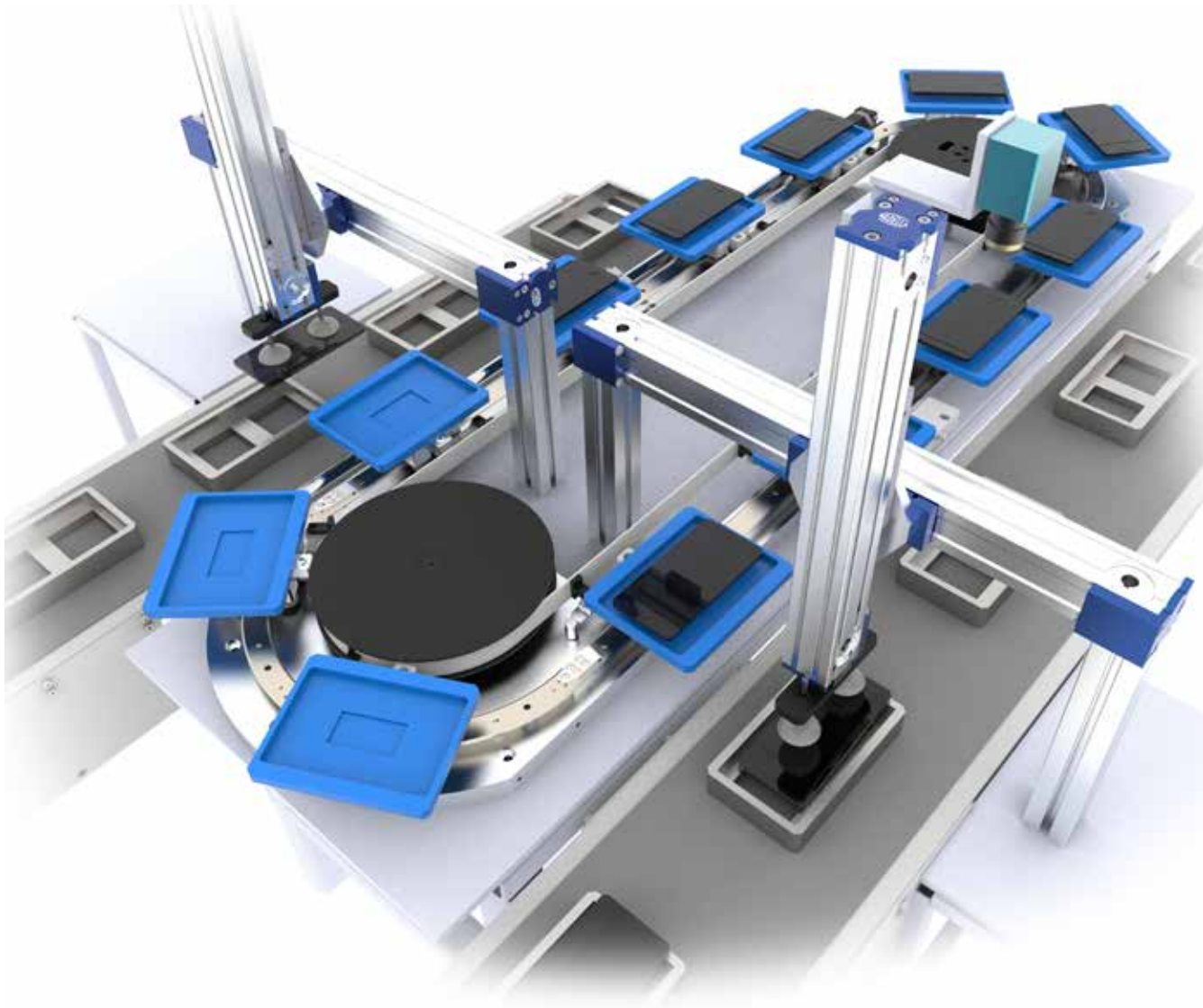

BOTTLING LINE

Bottling line consists of both AXNRQ Circular System and AXN actuators for bottling, sealing, testing, marking and packaging processes. This line provides a space-saving automatic solution with high consistency.



TECHNICAL FEATURES APPLICATION EXAMPLES

BATTERY ASSEMBLY LINE

Battery assembly line consists of a big radius AXNRO Circular System paired with articulated robots. The high quality of Nadella rollers guarantees remarkable load capacity and long service time.

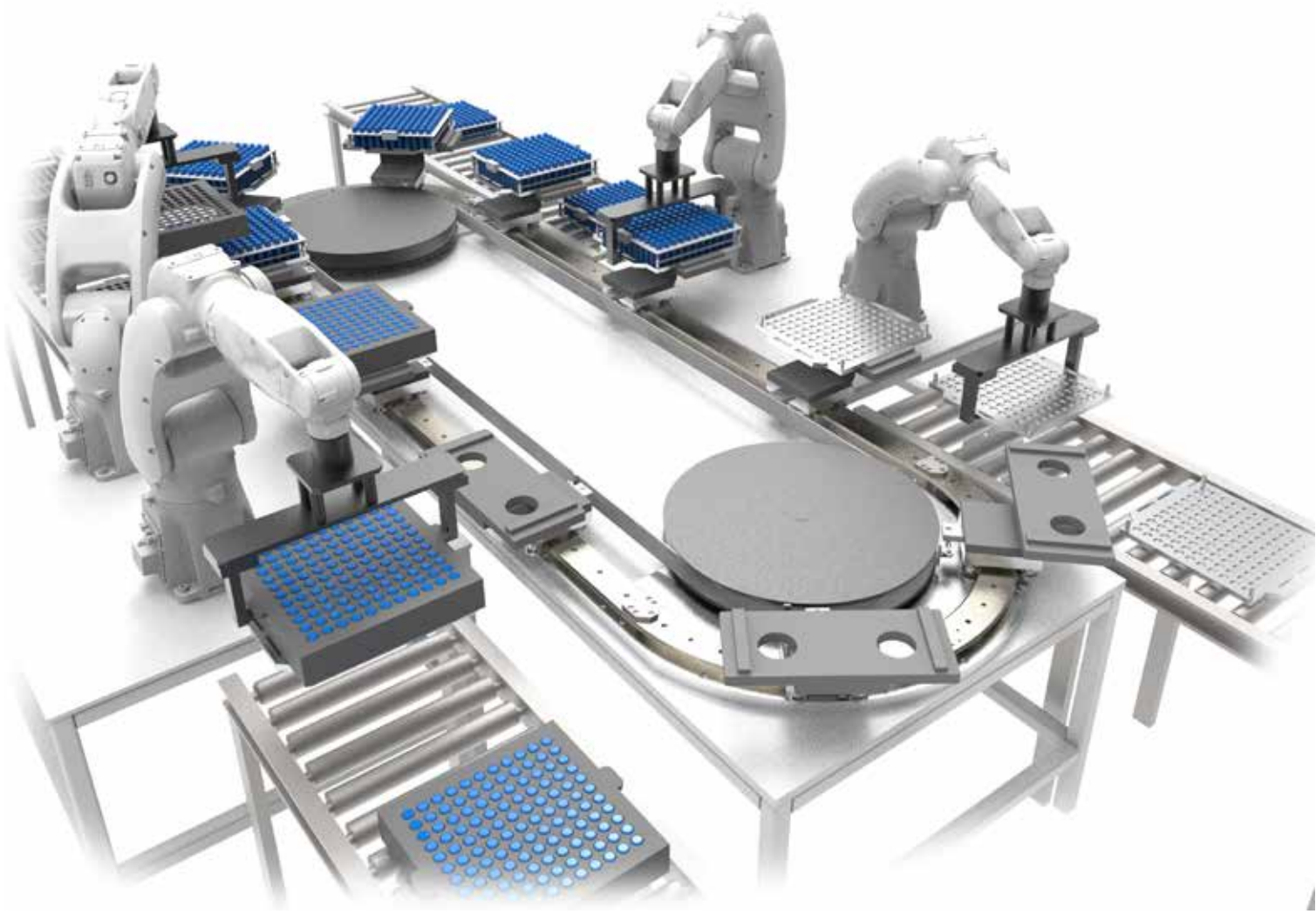

TECHNICAL FEATURES APPLICATIONS EXAMPLES

High Speed Conveyor

Two AXNRO Circular Systems can be positioned parallel to each other to serve as a double row conveyor, developed specifically for high speed and precision positioning. All floating rollers on one side provide self alignment, which eases the parallelism tolerance of the two bases during mounting and results in a steady conveyor system.

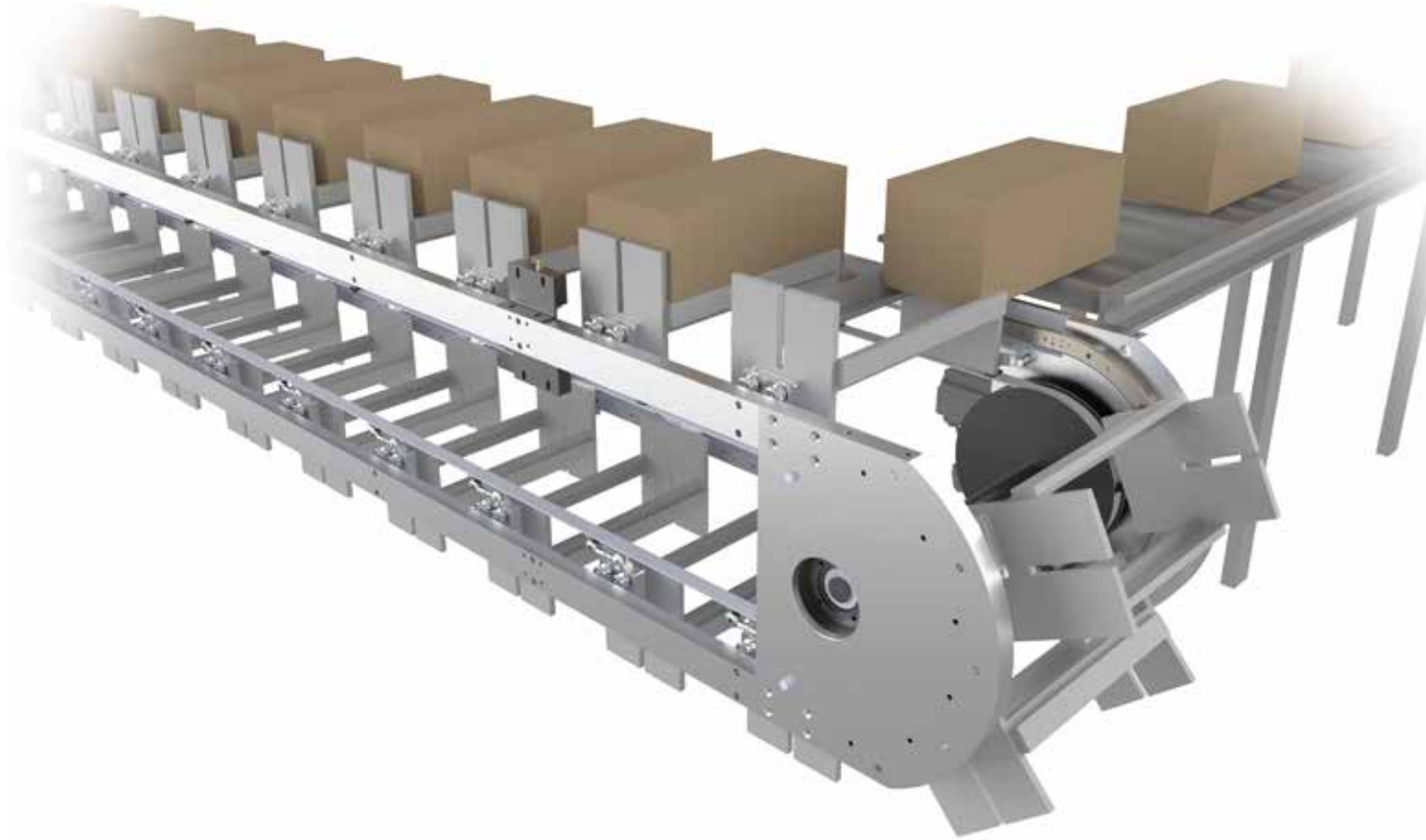

TECHNICAL FEATURES

SPARE PARTS

5.5

SPARE PARTS

AXNR system is designed to work for a long time. Anyway some parts are subject to wear and spare parts can be ordered to prevent equipment downtime. When ordering spare parts for already existing modules please provide the serial number printed on the unit.

Spare part list (in bold suggested):

- **Belt (false teeth included)**
- **Lubricator felts**
- Belt and pulleys
- Complete carriage (see carriage ordering code)
- Connection between carriage and belt
- Carriage locating cam
- Positioning system cam follower
- Positioning system air cylinder
- Complete positioning system unit
- Guide rollers (concentric and eccentric)
- Gearbox
- Home sensor
- Home sensor with fitting

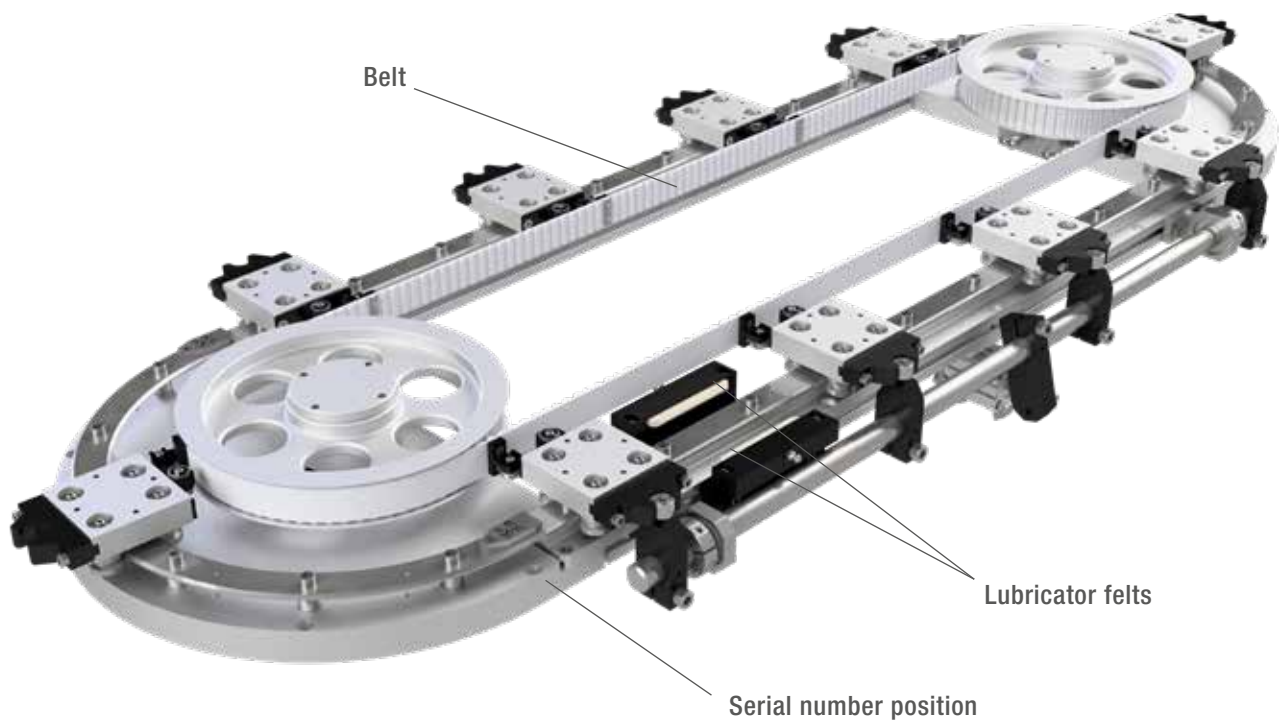

TECHNICAL FEATURES ORDER CODES

AXNR SYSTEM

ORDER CODE

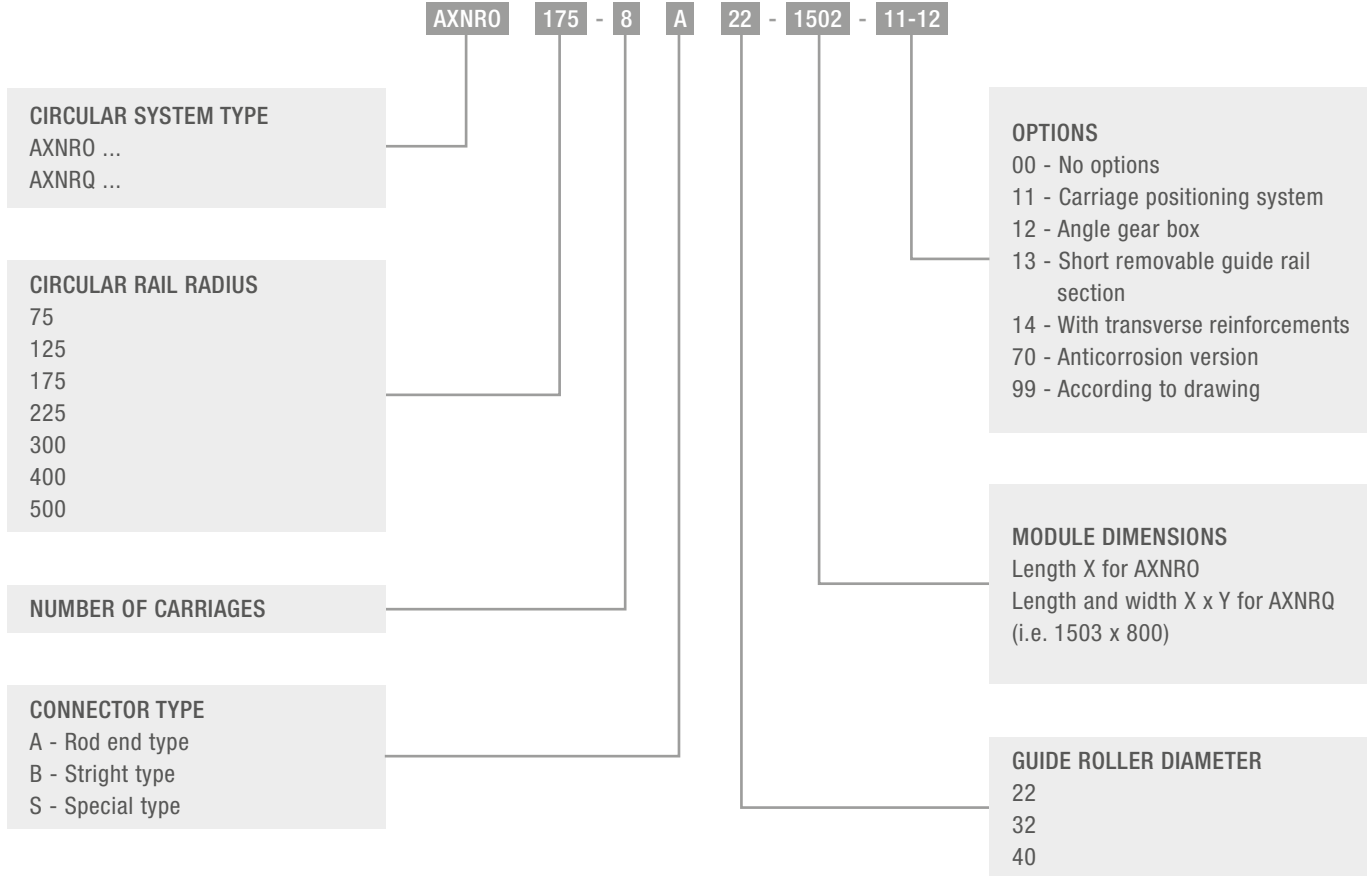

CARRIAGE

ORDER CODE

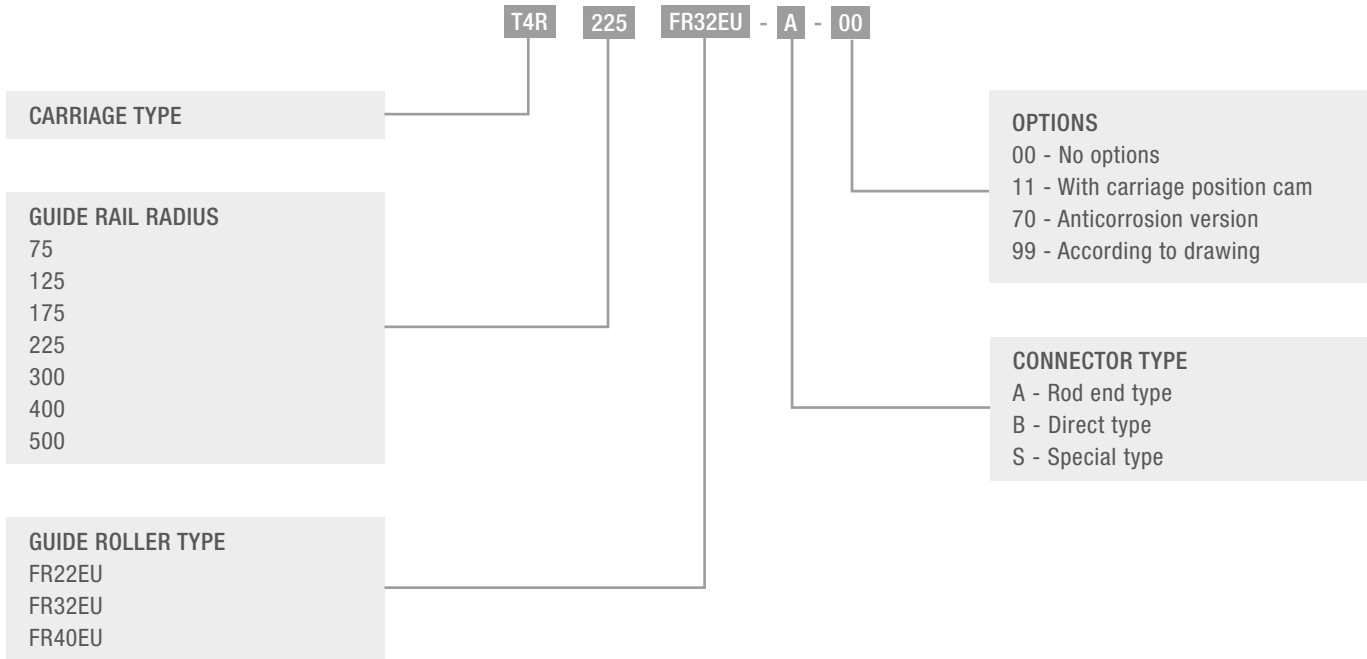

NOTE

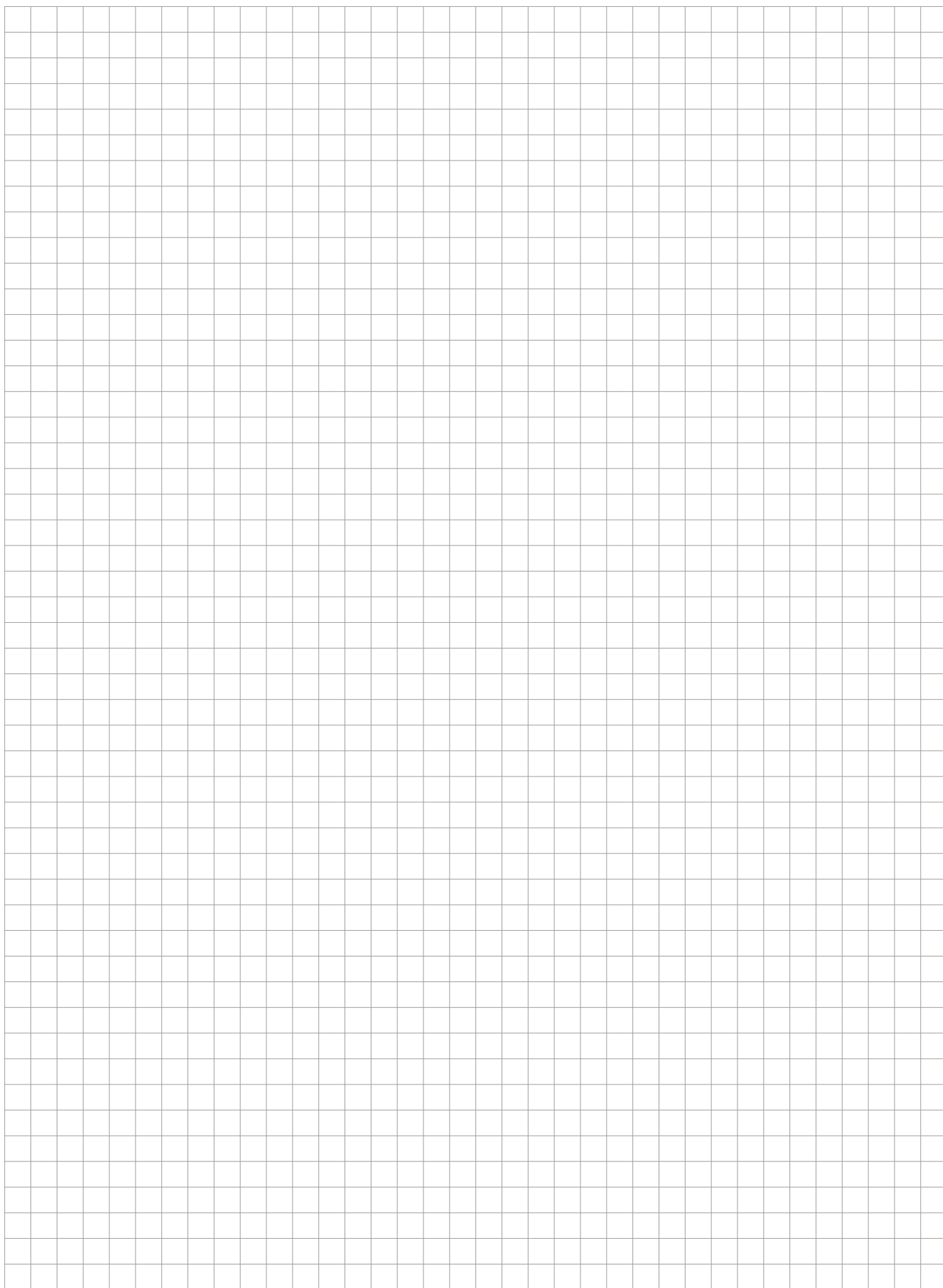



屠喜(Tony) | 商务技术总监

亿登(上海)自动化技术有限公司

Eden (shanghai) Automation Technology CO., LTD

地址:上海市闵行区陈行路2388号5号4楼401-19室(漕河泾浦江科技广场)

Add: Room P11 Buding 5, No. 2388 Chenhang Road, MinHang district, Shanghai

手机 Mobile: (+86) 139 1826 7864

电话 Phone: 021-51029898

传真 Fax: 021-51029899

邮箱 mail:sale@edenmotion.com

网址 Web: www.edenmotion.com



NADELLA / nadella.com

DURBAL / durbal.com

CHIAVETTE UNIFICATE / chiavette.com

IPIRANGA / ipirangahusillos.com

SHUTON / shuton.com

THE SPECIALIST FOR MOTION TECHNOLOGY

AXNR211EN